



Body Repair Manual Welding & Sectioning Guideline Revisions

(Supersedes original publication, issued **April 2014**, to clarify procedures and add the latest information)

OVERVIEW

In response to requests from the collision industry as the amount and tensile strength of steels used in our vehicles increase, Acura has made some significant changes to the approved welding methods and parts sectioning guidelines published in the body repair manuals. These changes will be integrated as each model's body repair manual is revised. The changes described here apply to all models and supersede previously published information.

WELDING GUIDELINES

Approved Welding Methods (Revised):

MAG butt welding is now an approved repair method for steel parts up to and including 780 MPa.

- The previous limit for butt welding was 590 MPa.
- The table at right lists approved welding methods.
- To minimize the heat-affected zone (HAZ), butt welds on 780 MPa steel must be done as quickly as possible, while maintaining adequate penetration.
- MAG plug welding is now allowed on 1,500 MPa (hot stamp) steel parts in select locations only as specified in the BRM.
- Welding instructions must be followed exactly as specified to ensure adequate weld strength.

Steel Part Tensile Strength (MPa)	Welding Method		
	Spot Weld	MAG Welding	
		Plug	Butt
<590	○	○	○
590	○	○	○
780	○	○	○
980	○	○	X
1,500	○	○*	X

Welding Methods For Steel Parts
 (○ = Approved X = Not Approved)
 ○* = Approved Only as Specified In BRM

Weld-Through Primer Guidelines (Revised):

- When doing squeeze-type resistance spot welding (STRSW), apply a zinc-rich weld-through primer, or spot sealer, to bare steel areas being welded and wipe off any excess. Use approved respiratory protection when working around these primers.
- Weld-through primer should **not** be used when doing MAG plug, MAG butt, or MIG Brazing. Further study has shown that weld-through primers can negatively affect weld or joint quality.
- When doing MAG plug and butt welding, or MIG brazing, remove only enough of the factory e-coat to allow bare metal in the weld or joint area. Then, apply corrosion-inhibiting primer over the completed weld or joint.
- Refer to the body repair manual for complete information.

MAG Welding Wire Selection Guidelines:

- Welding wire used during high-strength steel repair must have a tensile strength equal to, or greater than the lowest tensile strength of the parts being welded.
- Typical ER70S-6 wire has a minimum tensile strength of 70 ksi (483 MPa). This wire can be used when welding up to 440 MPa steel parts.
- This table shows the relationship of steel tensile strength (MPa) to the minimum welding wire tensile strength (ksi).

Steel Tensile (MPa)	Wire Tensile (ksi)
590	≥86
780	≥113
980	≥142

(1,000 psi = 1 ksi)

High-Strength MAG Welding Wire Availability (Revised):

- Bosch DS980J solid welding wire is no longer available.
- The Honda-approved replacement for DS980J wire is 0.8 mm diameter Bohler Union X96, which has a rated tensile strength of 980 MPa (142 ksi).
- This wire, or an approved equivalent, **must** be used when doing MAG welding procedures on steel parts from 590 – 980 MPa.
It **may** also be used when MAG welding 270 – 440 MPa steel parts.
- Bohler Union X96 wire is supplied in 11 lb. (5 kg) rolls and may be ordered from the following North American vendors:



Bohler Union X96
(980 MPa) MAG Wire

Vendor Name	Vendor P/N	Ordering Website	Phone Number
Dealer Equipment & Services (DES) Canada	HWW-98008	https://www.techniciantools.net	1-866-868-3372
Pro Spot Welding Systems	50-7040	http://prospot.com	1-877-776-7768
Honda and Acura Tool & Equipment Program	PRO50740	https://honda.snapon.com	1-866-346-8858

NOTE: Vendors obtain wire supplies independently. Please contact each vendor about availability and pricing.

MIG Brazing Wire Requirements and Availability (Revised):

- Required MIG brazing wire is silicon bronze (ERCuSi-A or CuSi-3), 0.8 mm diameter.
- Silicon bronze wire is also available from the above vendors. It is also commercially available.

SHIELDING GAS REQUIREMENTS

NOTE: In this publication and the body repair manuals, gas metal arc welding (GMAW) is referred to by the following subtypes:

MIG Welding/Brazing = Metal Inert Gas welding or brazing

- Argon is inert and does not react with the molten weld pool or brazing operation.
- The required MIG brazing shielding gas is 100% argon (Ar).

MAG Welding = Metal Active Gas welding

- The preferred shielding gas is C20. A mixture of 80% argon (Ar) and 20% carbon dioxide (CO₂), C20 produces a more stable arc, less weld spatter, and better weld quality/appearance.
- C25 shielding gas, a mixture of 75% argon (Ar) and 25% carbon dioxide (CO₂), is also acceptable.
- These are considered active gases because CO₂ undergoes a limited reaction with the molten weld pool.



USE OF HEAT DURING BODY STRAIGHTENING AND REPAIR

When you are doing body straightening and repair procedures, follow these guidelines:

- **Do not** apply heat to any body part during straightening. This may compromise the internal structure and strength of high-strength steel parts.
- Any part that has heat applied to it during straightening **must** be replaced with new parts.
- Ignoring these instructions may significantly reduce occupant protection in any subsequent collision.

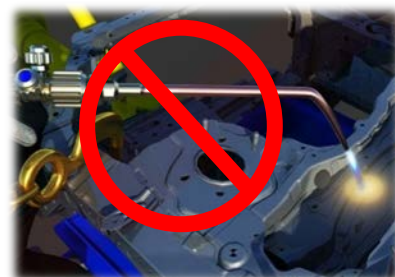

Do Not Heat During Straightening

PARTIAL PANEL REPLACEMENT AT FACTORY SEAMS

When you are determining whether to replace a body part as supplied, or do a partial replacement at the factory seams, follow these guidelines:

- Replacement of body service parts as supplied at factory seams is the preferred repair method, except when it may cause unnecessary or excessive intrusion into the body structure.
- In these cases, the service part may be disassembled at factory seams as required to replace only the damaged portion.
- For example, if only the vehicle's rear wheelhouse is damaged, that part may be removed from the rear inner panel service part assembly at the factory seams and installed on the vehicle.
- Note that there is **not** a BRM replacement procedure for rear inner panels because they are rarely installed as a complete unit.
- All basic welding & sectioning guidelines specified in the service information **must** be observed during partial panel replacement.

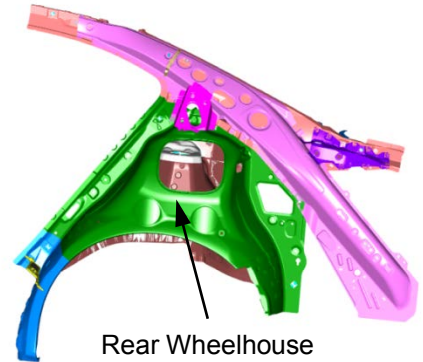

Rear Inner Panel Service Part Example

STEEL PARTS SECTIONING GUIDELINES

Replacement of steel parts at factory seams and matching the replacement part configuration remain the preferred repair methods. However, these methods alone are not always practical nor cost effective in all body repair situations. While some limited sectioning procedures are provided in the body repair manuals, it is not possible to develop published procedures covering every type and angle of impact.

The revised guidelines detailed below are intended as "basic rules" for properly trained collision repair professionals to use when sectioning steel parts on Honda and Acura vehicles.

Various high-strength and ultra-high-strength steel materials with different sheet thicknesses and strengths are applied in many places that vary with body design in order to increase collision safety performance, body stiffness, and weight reduction. Stiffening members are also applied inside some steel parts (patches, reinforcements, stiffeners, etc.)

Follow these guidelines to avoid an unsafe repair:

- Outer body and floor panels may be sectioned as necessary. Specific sectioning procedures are not provided in the body repair manual.
- Depending on the type of vehicle damage, steel parts with a tensile strength of 780 MPa or less may be sectioned **if all three of the following conditions are met:**
 1. Sectioning must be done in a single-layer area of the part.
 2. Multi-layer internal steel reinforcements and stiffeners must not be cut.
 3. Do not section in load bearing areas, such as engine, transmission, or suspension mounting points.
- To determine if a part has a single-layer area that can be sectioned, do the following:
 - Check the body construction pages in the General Information section of the appropriate body repair manual to determine the steel grade(s) and part configurations of the parts being replaced.
 - Inspect the original and replacement parts to confirm if there are internal reinforcements and/or stiffeners.
 - Spot welds not directly on a flange or joint indicate a reinforcement or stiffener inside.
 - The body repair manual Replacement section shows some internal reinforcements as a dotted line.
- If any of the above sectioning conditions cannot be met, replace those body structural components (stiffeners, reinforcements, and other multi-layered steel parts) as assemblies that match the replacement parts configuration.

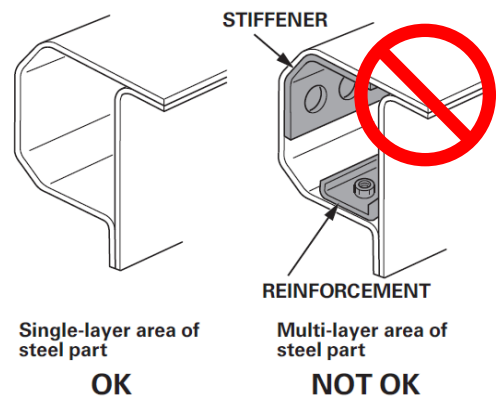

Sectioning Area Examples